

Guide units EAGF, for electric cylinders

FESTO

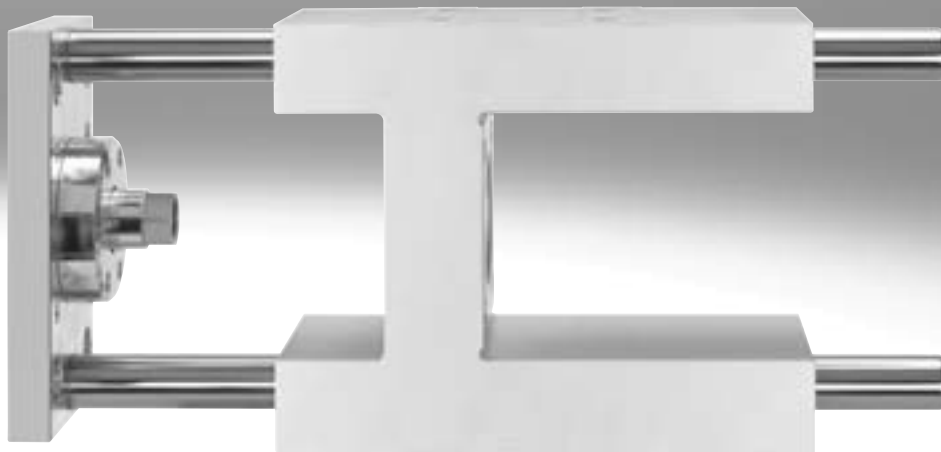

Festo Core Range
Covers the majority of your automation tasks

Worldwide:

Always in stock

Superb:

Festo quality at an attractive price

Easy:

Simplified procurement and warehousing

★ Generally ready for shipping ex works in 24 hours

In stock at 13 Service Centres worldwide

More than 2200 products

★ Generally ready for shipping ex works in 5 days

Assembled for you at 4 Service Centres worldwide

Up to 6×10^{12} variants per product family

Just look
for the
star!

Key features

At a glance

The guide unit EAGF is used to protect electric cylinders against torsion when these are subjected to high torque loads. It offers a high level of guide precision for workpiece handling and other applications.

The interface makes it quick and easy to mount on many Festo drives/axes.

For electric cylinders EPCC → page 4

For electric cylinders ESBF → page 14

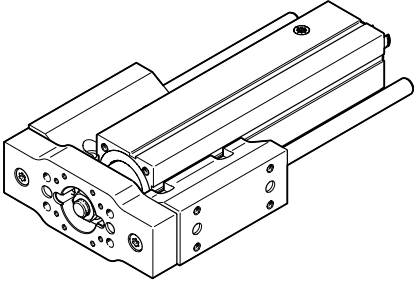

For electric cylinders EPCO → page 24



Type codes

001	Series
EAGF	Guide unit, for electric cylinder

002	Allocation
P1	Version P1 (EPCO)
P2	Version P2 (EPCC)
V2	Version V2 (ESBF)

003	Guide
KF	Recirculating ball bearing guide

004	Size [mm]
16	16
25	25
32	32
40	40
45	45
50	50
60	60
63	63
80	80
100	100

005	Stroke [mm]
50	50
100	100
150	150
200	200
300	300
320	320
400	400

Datasheet

⊘ Diameter
32, 45, 60 mm

 www.festo.com

┆ Stroke length
25 ... 500 mm

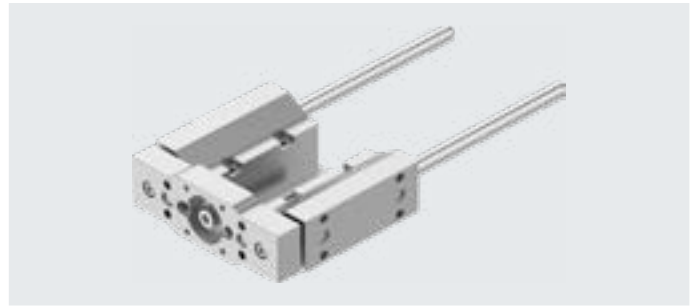

General technical data				
Size		32	45	60
Stroke	[mm]	25, 50, 75, 100, 125, 150, 175, 200	25, 50, 75, 100, 125, 150, 175, 200, 250, 300	25, 50, 75, 100, 125, 150, 175, 200, 250, 300, 350, 400, 500
Design		Guide		
Guide		Recirculating ball bearing guide		
Displacement force	[N]	1.6	2	3
Reversing backlash	[μm]	0		
Permissible speed	[m/s]	1		
Permissible acceleration	[m/s ²]	25		
Type of mounting		Via female thread		
Mounting position		Any		

Operating and environmental conditions				
Size		32	45	60
Ambient temperature	[°C]	0 ... +60		
Degree of protection		IP40		
Corrosion resistance class CRC ¹⁾		0		

1) Additional information www.festo.com/x/topic/kbk

Weight [g] (for calculation → page 6)				
Size		32	45	60
Basic weight with 0 mm stroke		613	1037	1614
Additional weight per 10 mm stroke		7.9	12.3	17.8
Moving mass with 0 mm stroke		170	342	583
Additional mass per 10 mm stroke		7.9	12.3	17.8

Centre of gravity of the moving mass [mm] (for calculation → page 6)				
Size		32	45	60
With 0 mm stroke		26	25	31
Supplement per 10 mm stroke		4.3	4.3	4.3

Datasheet

Materials

Sectional view

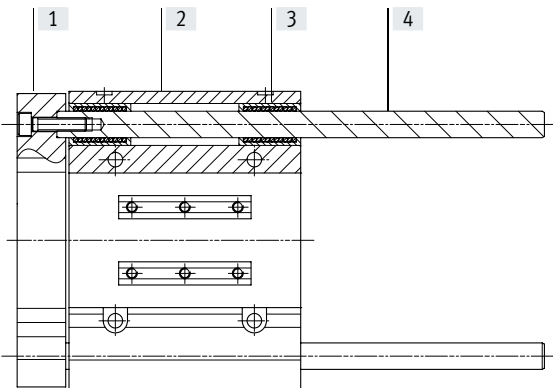

Guide unit		
[1]	Yoke plate	Anodised wrought aluminium alloy
[2]	Housing	Anodised wrought aluminium alloy
[3]	Bearings	Steel
[4]	Guiding rod	Hard-chromium plated tempered steel
-	Note on materials	RoHS-compliant
-	LABS (PWIS) conformity	VDMA24364 zone III

Load values

The indicated forces and torques refer to the centre of the guide.

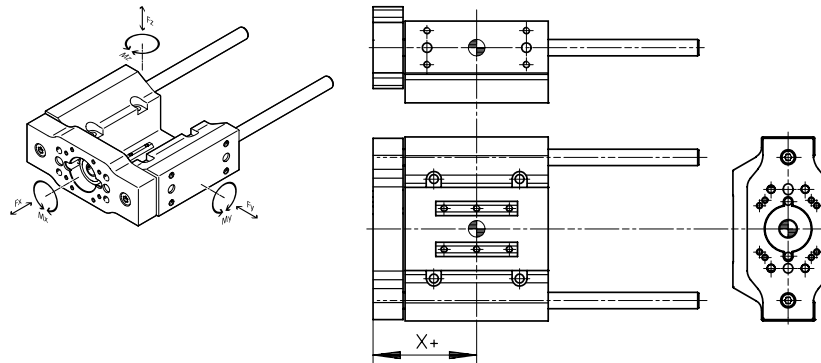

If the guide unit is subjected to several of the indicated forces and torques at the same time, the following equation must be satisfied in addition to the indicated maximum loads:

Calculating the load comparison factor:

$$f_v = \frac{|F_{y1}|}{F_{y2}} + \frac{|F_{z1}|}{F_{z2}} + \frac{|M_{x1}|}{M_{x2}} + \frac{|M_{y1}|}{M_{y2}} + \frac{|M_{z1}|}{M_{z2}} \leq 1$$

F_1/M_1 = dynamic value

F_2/M_2 = maximum value

Distance X (for calculation → page 6)

Size	32	45	60
Dimension X [mm]	54	63	76

Max. permissible forces and torques

Size	32	45	60
Static			
F_{Vmax}/F_{Zmax} [N]	355	415	510
M_{Xmax} [Nm]	13	19	27
M_{Ymax}/M_{Zmax} [Nm]	9	12	20
Dynamic (for a service life of 5000 km)			
F_{Vmax}/F_{Zmax} [N]	160	320	380
M_{Xmax} [Nm]	6	15	20
M_{Ymax}/M_{Zmax} [Nm]	4	10	15

Datasheet

Calculating the service life

The service life of the guide depends on the load. To provide a rough indication of the service life of the guide, the graph below plots the load comparison factor f_v against the service life ratio q .

These values are only theoretical. You must consult your local contact person at Festo for load comparison factors f_v greater than 1.5.

Load comparison factor f_v as a function of service life ratio q

Example: The effect on the service life, deviating from the specified reference service life, can be determined using the service life ratio q :

Assuming: Reference service life = 5000 km
Required service life = 3000 km

$$q = \frac{3000 \text{ km}}{5000 \text{ km}} = 0,6$$

The graph gives a load comparison factor f_v of 1.2. This means that the permissible total load can be utilised up to 120%.

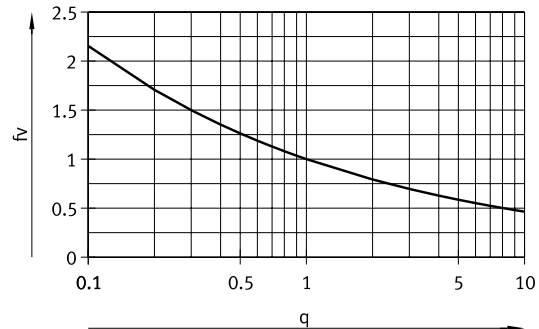

$f_v > 1.5$ are only theoretical comparison values.

Calculation example

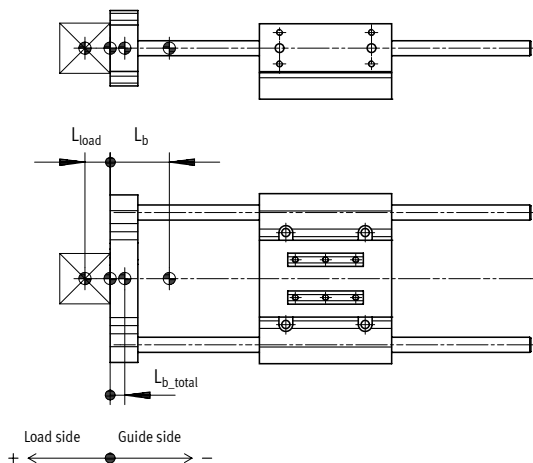

L_b = Centre of gravity of the moving mass of the guide unit

L_{load} = Centre of gravity of payload

L_{b_total} = Centre of gravity of the total moving mass

Length measurements should be provided with plus/minus signs as shown in the figure:

$L_{b_total} > 0$ = Centre of gravity of the moving mass is on the payload side

$L_{b_total} < 0$ = Centre of gravity of the moving mass is on the guide side

Assuming:

- Guide unit: EAGF-P2-KF-45-200
- Stroke length: $H = 200 \text{ mm}$
- Centre of gravity of payload: $L_{load} = 15 \text{ mm}$
- Payload: $m_{Load} = 2 \text{ kg}$
- Acceleration: $a_x = a_y = 2 \text{ m/s}^2$, $a_z = 0 \text{ m/s}^2$

To be determined:

- Loads F_{y_dyn}/F_{z_dyn} and $M_{x_dyn}/M_{y_dyn}/M_{z_dyn}$
- Functional operation with combined load
- Expected service life

Datasheet

Calculation example

Solution:

Moving mass:

$$m_{b_total} = m_b + m_{load} \quad (m_b = m_{0b} + H \times m_{Hb})$$

From table → page 4

$$m_{0b} = 0.342 \text{ kg}$$

$$m_{Hb} = 0.0123 \text{ kg/10 mm}$$

$$m_b = 0.342 \text{ kg} + 200 \text{ mm} \times 0.0123 \text{ kg/10 mm} = 0.588 \text{ kg}$$

$$m_{b_total} = 0.588 \text{ kg} + 2 \text{ kg} = 2.588 \text{ kg}$$

m_b = Moving mass of the guide unit

m_{0b} = Moving mass with 0 mm stroke

m_{Hb} = Additional mass per 10 mm stroke

H = Stroke length

Centre of gravity of the moving mass

$$L_{b_ges} = \frac{L_1 \cdot m_1 + L_b \cdot m_b}{m_{b_ges}} \quad (L_b = L_{0b} + H \times L_{Hb})$$

From table → page 4

$$L_{0b} = 25 \text{ mm}$$

$$L_{Hb} = 4.3 \text{ mm/10 mm}$$

$$L_b = 25 \text{ mm} + 200 \text{ mm} \times 4.3 \text{ mm/10 mm} = 111 \text{ mm}$$

$$L_{b_ges} = \frac{(+15 \text{ mm}) \cdot 2 \text{ kg} + (-111 \text{ mm}) \cdot 0.588 \text{ kg}}{2.588 \text{ kg}} = -14 \text{ mm}$$

L_b = Centre of gravity of the moving mass of the guide unit

m_b = Moving mass of the guide unit

L_1 = Centre of gravity of payload

m_1 = Payload

L_{0b} = Centre of gravity of the moving mass with 0 mm stroke

L_{Hb} = Additional centre of gravity of the moving mass per 10 mm stroke

Length measurements should be provided with plus/minus signs as shown in the figure:

$L_{b_total} > 0$ = Centre of gravity of the moving mass is on the payload side

$L_{b_total} < 0$ = Centre of gravity of the moving mass is on the guide side

Loads F_{y_dyn}/F_{z_dyn} and $M_{x_dyn}/M_{y_dyn}/M_{z_dyn}$

$$F_{y_dyn} = m_{b_total} \times a_y = 2.588 \text{ kg} \times 2 \text{ m/s}^2 = 5 \text{ N}$$

$$F_{z_dyn} = m_{b_total} \times (g + a_z) = 2.588 \text{ kg} \times (9.81 \text{ m/s}^2 + 0 \text{ m/s}^2) = 25 \text{ N}$$

From table → page 5

Dimension X = 63 mm

$$M_{y_dyn} = F_{z_dyn} \times (\text{dimension X} + \text{stroke} + L_{b_total}) = 25 \text{ N} \times (63 \text{ mm} + 200 \text{ mm} + (-14 \text{ mm})) = 6.3 \text{ Nm}$$

$$M_{z_dyn} = F_{y_dyn} \times (\text{dimension X} + \text{stroke} + L_{b_total}) = 5 \text{ N} \times (63 \text{ mm} + 200 \text{ mm} + (-14 \text{ mm})) = 1.3 \text{ Nm}$$

Functional operation with combined load

Max. values from table → page 5

$$F_{y_max} = 320 \text{ N}$$

$$F_{z_max} = 320 \text{ N}$$

$$M_{x_max} = 15 \text{ Nm}$$

$$M_{y_max} = 10 \text{ Nm}$$

$$M_{z_max} = 10 \text{ Nm}$$

$$f_v = \frac{|F_{y1}|}{F_{y2}} + \frac{|F_{z1}|}{F_{z2}} + \frac{|M_{x1}|}{M_{x2}} + \frac{|M_{y1}|}{M_{y2}} + \frac{|M_{z1}|}{M_{z2}} \leq 1$$

$$f_v = \frac{5 \text{ N}}{320 \text{ N}} + \frac{25 \text{ N}}{320 \text{ N}} + \frac{0 \text{ Nm}}{15 \text{ Nm}} + \frac{6.3 \text{ Nm}}{10 \text{ Nm}} + \frac{1.3 \text{ Nm}}{10 \text{ Nm}} = 0.86 \leq 1$$

F_1/M_1 = dynamic value

F_2/M_2 = maximum value

Expected service life

$$L = \frac{L_{ref}}{f_v^3} = \frac{5000 \text{ km}}{0.86^3} = 7930 \text{ km}$$

Datasheet

Max. payload F and torque M as a function of projection A

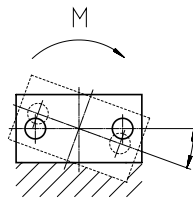
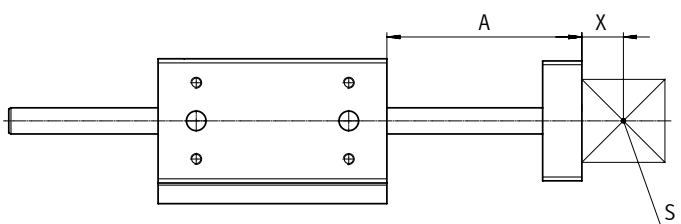

- A = Projection
- X = Distance to centre of gravity of the payload
- S = Centre of gravity of the payload
- M = Torque

Explanation of how to read the graphs in the case of a combined load

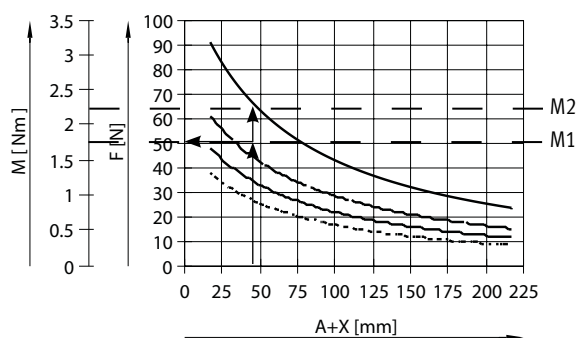

- Determine projection (50 mm)
- Enter lateral force (50 N)
- Enter distance from curve
- Permitted torque is the difference between M2 and M1

- Running performance of 500 km
- - - - - Running performance of 2500 km
- - - - - Running performance of 5000 km
- Running performance of 10000 km

Size 32

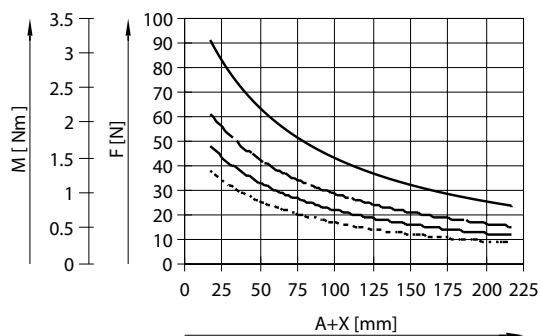

Size 45

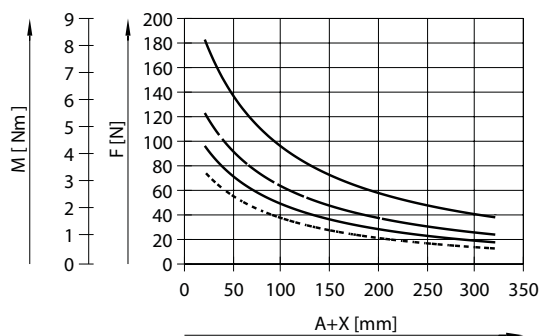

Size 60

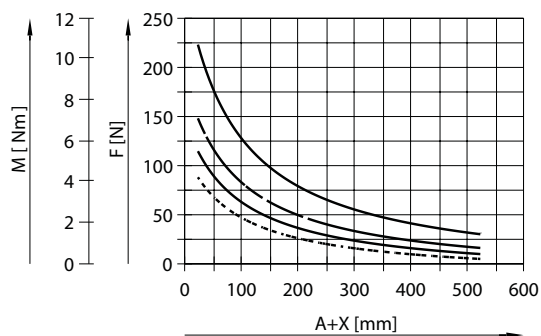

- Running performance of 500 km
- - - - - Running performance of 2500 km
- - - - - Running performance of 5000 km
- Running performance of 10000 km

Datasheet

Deflection f_{dead} (due to dead weight) as a function of projection A

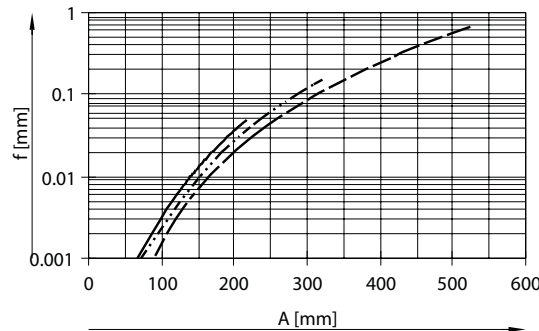
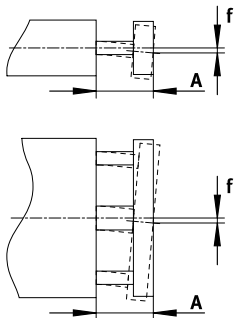

— EAGF-P2-KF-32
 - · - · - · EAGF-P2-KF-45
 - - - EAGF-P2-KF-60

Deflection f_{standard} (due to lateral force) as a function of projection A

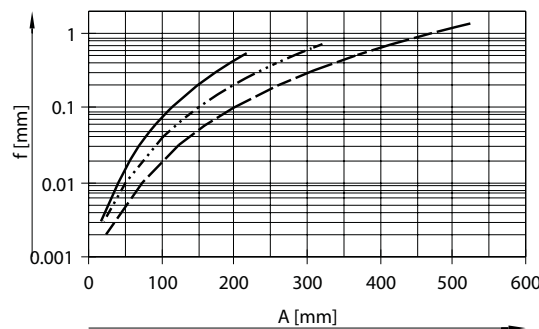
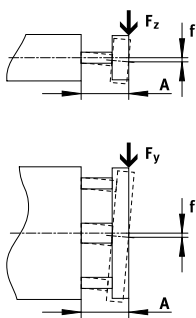

— EAGF-P2-KF-32
 - · - · - · EAGF-P2-KF-45
 - - - EAGF-P2-KF-60

The maximum permissible lateral force must not be exceeded.

$$f_1 = \frac{F_1}{F_2} \cdot f_2$$

$$F_2 = 10 \text{ N}$$

A = Projection of guide rod

f_1 = Deflection due to lateral force

F_1 = Lateral force

F_2 = Standardised lateral force

f_2 = Deflection due to standardised lateral force (value from graph)

Incline α (due to torque) as a function of projection A

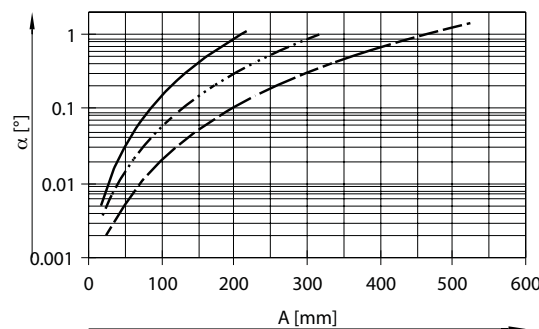
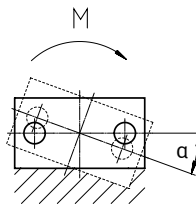

— EAGF-P2-KF-32
 - · - · - · EAGF-P2-KF-45
 - - - EAGF-P2-KF-60

$$\alpha_1 = \frac{M_1}{M_2} \cdot \alpha_2$$

$$M_2 = 2 \text{ Nm}$$

(valid for $\alpha \leq 10^\circ$)

A = Projection of guide rod

α_1 = Incline due to torque

M_1 = Torque

M_2 = Standardised torque

α_2 = Deflection due to standardised lateral force (value from graph)

Datasheet

Dimensions

Download CAD data → www.festo.com

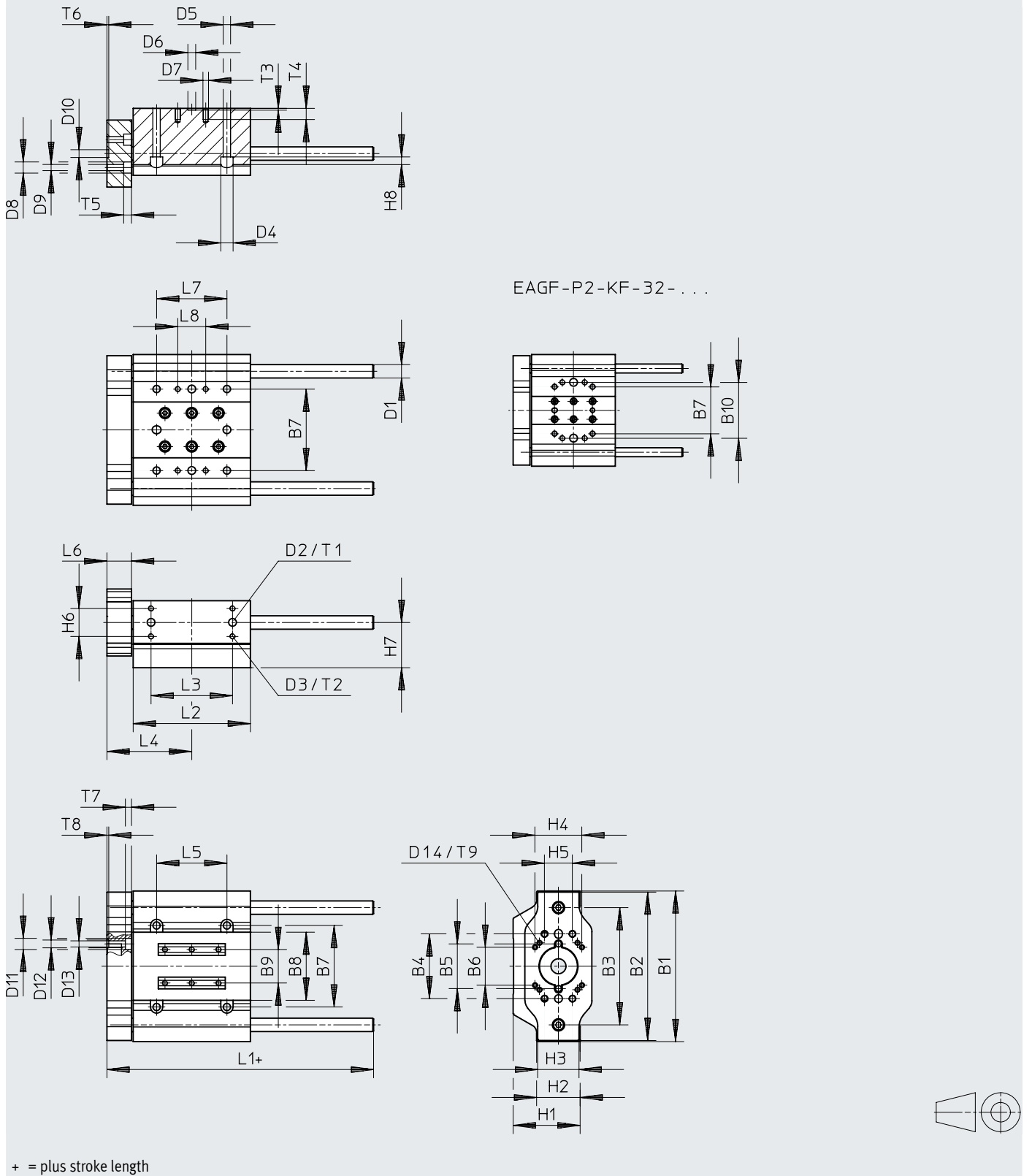

Datasheet

Size	B1	B2	B3	B4 ±0.1	B5 ±0.05	B6 ±0.1	B7	B8	B9	B10 ±0.05	D1 ∅	D2 ∅ H8
32	100	98	75	50	30	24	42	33	16	50	8	7
45	120	118	90	50	33	22.5	58	46	24	58	10	7
60	135	133	105	58	40	34	73	61	30	73	12	7

Size	D3	D4 ∅	D5 ∅	D6 ∅ H8	D7	D8 ∅	D9 ∅	D10 ∅ H8	D11 ∅	D12 ∅ H8	D13 ∅	D14
32	M5	8	4.5	7	M5	8	4.5	7	8	7	5	M3
45	M5	10	5.5	7	M5	10	5.5	7	10	7	5.5	M3
60	M5	11	6.6	7	M5	10	5.5	7	10	7	5.5	M4

Size	H1	H2	H3	H4 ±0.1	H5 ±0.05	H6 ±0.05	H7	H8	L1	L2	L3 ±0.05	L4
32	40	28	26	24	16	20	26	4.1	102	75	50	54
45	51	37	35	35	20	25	32.5	5.5	116	85	58	63
60	60	39	37	42	25	25	40.5	6.9	139	105	73	76

Size	L5	L6	L7 ±0.05	L8 ±0.05	T1 +0.1	T2	T3 +0.1	T4	T5	T6 +0.1	T7	T8 +0.1	T9
32	34	15	34	20	1.6	8.5	1.6	12	4.4	1.6	4.4	1.6	7
45	47	19	47	25	1.6	12	1.6	12	7	1.6	5.7	1.6	7
60	63	22	73	25	1.6	10	1.6	10	7	1.6	5.5	1.6	9

Datasheet

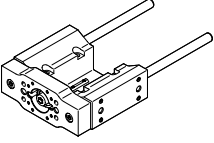
Ordering data				
Guide unit	Size	Stroke [mm]	Part no.	Type
	32	50	8158032	EAGF-P2-KF-32-50
		100	8158029	EAGF-P2-KF-32-100
		150	8158027	EAGF-P2-KF-32-150
		200	8158028	EAGF-P2-KF-32-200
	45	50	8158131	EAGF-P2-KF-45-50
		100	8158123	EAGF-P2-KF-45-100
		150	8158125	EAGF-P2-KF-45-150
		200	8158127	EAGF-P2-KF-45-200
		300	8158130	EAGF-P2-KF-45-300
	60	100	8158138	EAGF-P2-KF-60-100
		150	8158140	EAGF-P2-KF-60-150
		200	8158142	EAGF-P2-KF-60-200
		300	8158031	EAGF-P2-KF-60-300

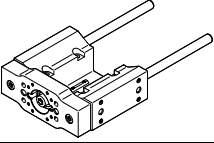
Ordering data				
Guide unit	Size	Stroke [mm]	Part no.	Type
	32	25, 75, 125, 175	8158030	EAGF-P2-KF-32-
	45	25, 75, 125, 175, 250	8158133	EAGF-P2-KF-45-
	60	25, 50, 75, 125, 175, 250, 350, 400, 500	8158150	EAGF-P2-KF-60-

Datasheet

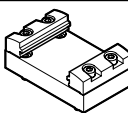
Accessories					
Ordering data					
	For size	Description	Part no.	Type	PU ¹⁾
Centring sleeve					
	32, 45, 60	<ul style="list-style-type: none"> For centring the drive For centring quarter turn actuators ERMO, ERMS on the yoke plate 	8146544	ZBH-7-B	10
	32		562959	ZBS-4	
	45	8146543	ZBH-5-B		
	60	8146544	ZBH-7-B		
Adapter kit					
	32	<ul style="list-style-type: none"> For mounting the mini slide EGSC, EGSS on the yoke plate 	8158473	EHAA-D-L2-32-L2-25	1
	45		8066713	EHAA-D-L2-32-L2-32	
	60		8066714	EHAA-D-L2-45-L2-45	

1) Packaging unit

Datasheet

⊘ Diameter
32 ... 100 mm

 www.festo.com

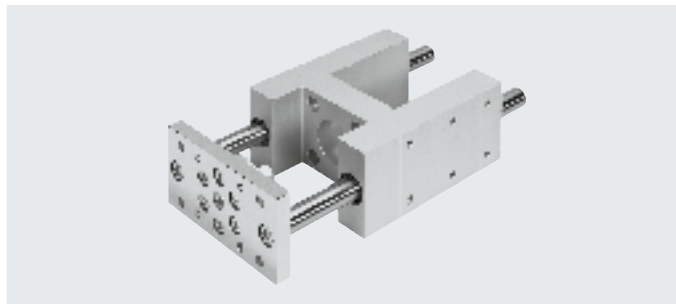

┆ Stroke length
1 ... 550 mm

General technical data

Size	32	40	50	63	80	100
Stroke [mm]	1 ... 500				1 ... 550	
Design	Guide					
Guide	Recirculating ball bearing guide					
Displacement force [N]	15				40	
Reversing backlash [μm]	0					
Type of mounting	Via female thread					
Mounting position	Any					
Ambient temperature [°C]	-20 ... +80°C					
Corrosion resistance class CRC ¹⁾	0					

1) Additional information www.festo.com/x/topic/kbk

Weight [g] (calculation example → page 16)

Size	32	40	50	63	80	100
Basic weight with 0 mm stroke	1685	2517	4059	5525	10517	13263
Additional weight per 10 mm stroke	18	32	49	49	76	76
Moving mass with 0 mm stroke	724	1283	2015	2560	5166	6148
Additional mass per 10 mm stroke	18	32	49	49	76	76

Centre of gravity of the moving mass [mm] (for calculation example → page 16)

Size	32	40	50	63	80	100
With 0 mm stroke	30	38	46	48	54	47
Supplement per 10 mm stroke	4.1	4.2	4.3	4.1	3.8	3.6

Materials

Sectional view

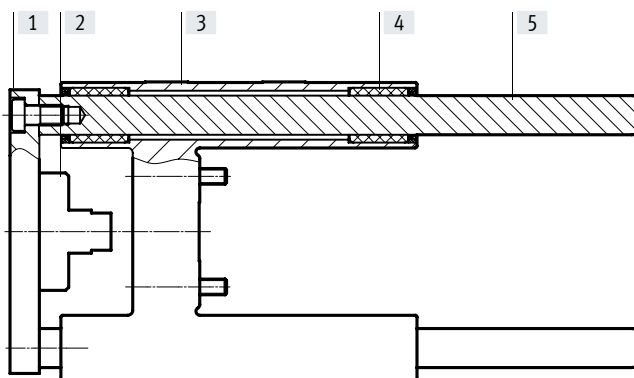

Guide unit	
[1] Yoke plate	Steel
[2] Compensating component	Steel
[3] Housing	Anodised wrought aluminium alloy
[4] Bearings	Steel
[5] Guiding rod	Steel
- Note on materials	RoHS-compliant

Datasheet

Load values

The indicated forces and torques refer to the centre of the guide.

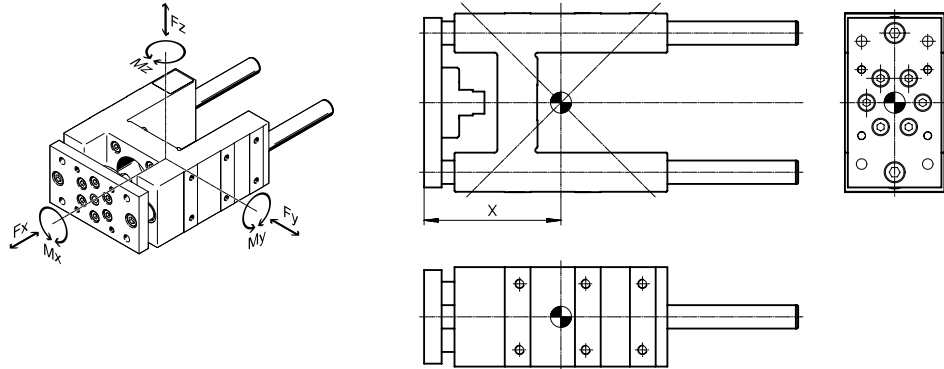

If the guide unit is subjected to several of the indicated forces and torques at the same time, the following equation must be satisfied in addition to the indicated maximum loads:

Calculating the load comparison factor:

$$f_v = \frac{|F_{y1}|}{F_{y2}} + \frac{|F_{z1}|}{F_{z2}} + \frac{|M_{x1}|}{M_{x2}} + \frac{|M_{y1}|}{M_{y2}} + \frac{|M_{z1}|}{M_{z2}} \leq 1$$

F_1/M_1 = dynamic value
 F_2/M_2 = maximum value

Distance X (calculation example → page 16)

Size		32	40	50	63	80	100
Dimension X	[mm]	83	85	99	117	142	145

Max. permissible forces and torques

Size		32	40	50	63	80	100
------	--	----	----	----	----	----	-----

Static

$F_{y_{max.}}/F_{z_{max.}}$	[N]	1020	1260	1600	1600	3120	3120
$M_{x_{max.}}$	[Nm]	38	55	83	95	231	268
$M_{y_{max.}}/M_{z_{max.}}$	[Nm]	46	65	89	115	259	267

Dynamic (for a service life of 5000 km)

$F_{y_{max.}}/F_{z_{max.}}$	[N]	750	1000	1260	1260	2300	2300
$M_{x_{max.}}$	[Nm]	28	44	65	75	170	198
$M_{y_{max.}}/M_{z_{max.}}$	[Nm]	34	52	70	90	191	197

Datasheet

Calculating the service life

The service life of the guide depends on the load. To provide a rough indication of the service life of the guide, the graph below plots the load comparison factor f_v against the service life ratio q .

These values are only theoretical. You must consult your local contact person at Festo for load comparison factors f_v greater than 1.5.

Load comparison factor f_v as a function of service life ratio q

Example: The effect on the service life, deviating from the specified reference service life, can be determined using the service life ratio q :

Assuming: Reference service life = 5000 km
Required service life = 3000 km

$$q = \frac{3000 \text{ km}}{5000 \text{ km}} = 0,6$$

The graph gives a load comparison factor f_v of 1.2. This means that the permissible total load can be utilised up to 120%.

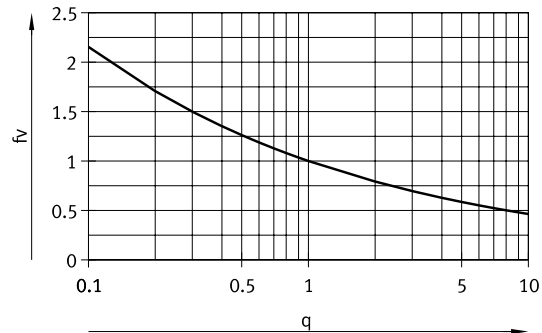

$f_v > 1.5$ are only theoretical comparison values.

Calculation example

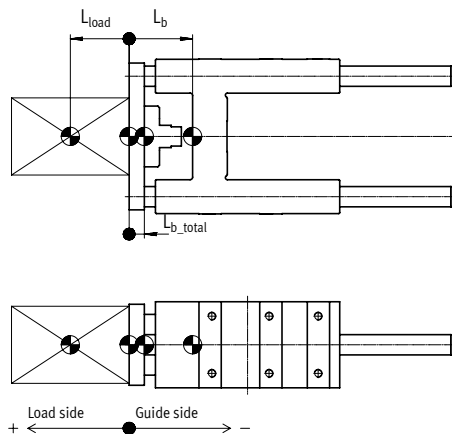

L_b = Centre of gravity of the moving mass of the guide unit

L_{load} = Centre of gravity of payload

L_{b_total} = Centre of gravity of the total moving mass

Length measurements should be provided with plus/minus signs as shown in the figure:

$L_{b_total} > 0$ = Centre of gravity of the moving mass is on the payload side

$L_{b_total} < 0$ = Centre of gravity of the moving mass is on the guide side

Assuming:

- Guide unit: EAGF-V2-KF-32-200
- Stroke length: $H = 200 \text{ mm}$
- Centre of gravity of payload: $L_{load} = 15 \text{ mm}$
- Payload: $m_{Load} = 5 \text{ kg}$
- Acceleration: $a_x = a_y = 2 \text{ m/s}^2$, $a_z = 0 \text{ m/s}^2$

To be determined:

- Loads F_{y_dyn}/F_{z_dyn} and $M_{x_dyn}/M_{y_dyn}/M_{z_dyn}$
- Functional operation with combined load
- Expected service life

Datasheet

Calculation example

Solution:

Moving mass:

$$m_{b_total} = m_b + m_{load} \quad (m_b = m_{0b} + H \times m_{Hb})$$

From table → page 14

$$m_{0b} = 0.724 \text{ kg}$$

$$m_{Hb} = 0.018 \text{ kg/10 mm}$$

$$m_b = 0.724 \text{ kg} + 200 \text{ mm} \times 0.018 \text{ kg/10 mm} = 1.084 \text{ kg}$$

$$m_{b_total} = 1.084 \text{ kg} + 5 \text{ kg} = 6.084 \text{ kg}$$

m_b = Moving mass of the guide unit

m_{0b} = Moving mass with 0 mm stroke

m_{Hb} = Additional mass per 10 mm stroke

H = Stroke length

Centre of gravity of the moving mass

$$L_{b_ges} = \frac{L_1 \cdot m_1 + L_b \cdot m_b}{m_{b_ges}} \quad (L_b = L_{0b} + H \times L_{Hb})$$

From table → page 14

$$L_{0b} = 30 \text{ mm}$$

$$L_{Hb} = 4.1 \text{ mm/10 mm}$$

$$L_b = 30 \text{ mm} + 200 \text{ mm} \times 4.1 \text{ mm/10 mm} = 112 \text{ mm}$$

$$L_{b_ges} = \frac{(+15 \text{ mm}) \cdot 5 \text{ kg} + (-112 \text{ mm}) \cdot 1.084 \text{ kg}}{6.084 \text{ kg}} = -8 \text{ mm}$$

L_b = Centre of gravity of the moving mass of the guide unit

m_b = Moving mass of the guide unit

L_1 = Centre of gravity of payload

m_1 = Payload

L_{0b} = Centre of gravity of the moving mass with 0 mm stroke

L_{Hb} = Additional centre of gravity of the moving mass per 10 mm stroke

Length measurements should be provided with plus/minus signs as shown in the figure:

$L_{b_total} > 0$ = Centre of gravity of the moving mass is on the payload side

$L_{b_total} < 0$ = Centre of gravity of the moving mass is on the guide side

Loads F_{y_dyn}/F_{z_dyn} and $M_{x_dyn}/M_{y_dyn}/M_{z_dyn}$

$$F_{y_dyn} = m_{b_total} \times a_y = 6.084 \text{ kg} \times 2 \text{ m/s}^2 = 12 \text{ N}$$

$$F_{z_dyn} = m_{b_total} \times (g + a_z) = 6.084 \text{ kg} \times (9.81 \text{ m/s}^2 + 0 \text{ m/s}^2) = 60 \text{ N}$$

From table → page 15

Dimension X = 83 mm

$$M_{y_dyn} = F_{z_dyn} \times (\text{dimension X} + \text{stroke} + L_{b_total}) = 60 \text{ N} \times (83 \text{ mm} + 200 \text{ mm} + (-8 \text{ mm})) = 16 \text{ Nm}$$

$$M_{z_dyn} = F_{y_dyn} \times (\text{dimension X} + \text{stroke} + L_{b_total}) = 12 \text{ N} \times (83 \text{ mm} + 200 \text{ mm} + (-8 \text{ mm})) = 3 \text{ Nm}$$

Functional operation with combined load

Max. values from table → page 15

$$F_{y_max} = 750 \text{ N}$$

$$F_{z_max} = 750 \text{ N}$$

$$M_{x_max} = 28 \text{ Nm}$$

$$M_{y_max} = 34 \text{ Nm}$$

$$M_{z_max} = 34 \text{ Nm}$$

$$f_v = \frac{|F_{y1}|}{F_{y2}} + \frac{|F_{z1}|}{F_{z2}} + \frac{|M_{x1}|}{M_{x2}} + \frac{|M_{y1}|}{M_{y2}} + \frac{|M_{z1}|}{M_{z2}} \leq 1$$

$$f_v = \frac{12 \text{ N}}{750 \text{ N}} + \frac{60 \text{ N}}{750 \text{ N}} + \frac{0 \text{ Nm}}{28 \text{ Nm}} + \frac{16 \text{ Nm}}{34 \text{ Nm}} + \frac{3 \text{ Nm}}{34 \text{ Nm}} = 0,7 \leq 1$$

F_1/M_1 = dynamic value

F_2/M_2 = maximum value

Expected service life

$$L = \frac{L_{ref}}{f_v^3} = \frac{5000 \text{ km}}{0,7^3} = 14000 \text{ km}$$

Datasheet

Max. payload F and torque M as a function of projection A

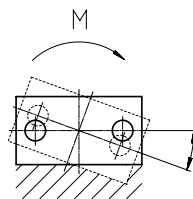
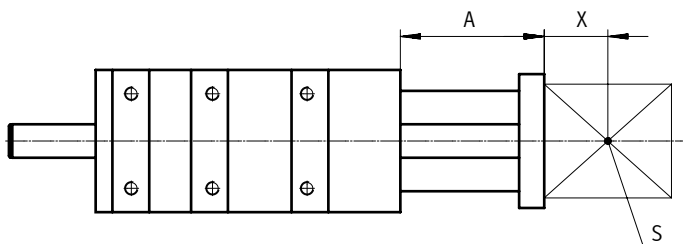

- A = Projection
- X = Distance to centre of gravity of the payload
- S = Centre of gravity of the payload
- M = Torque

Explanation of how to read the graphs in the case of a combined load

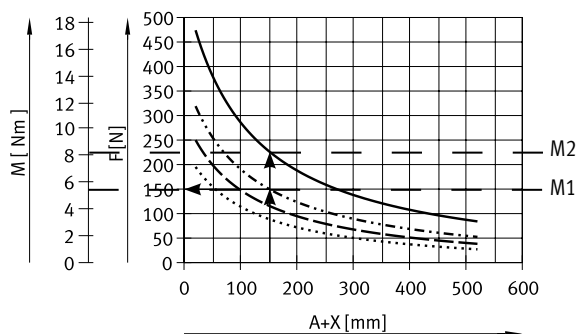

- Determine projection (150 mm)
- Enter lateral force (150 N)
- Enter distance from curve
- Permitted torque is the difference between M2 and M1

- Running performance of 500 km
- Running performance of 2500 km
- - - Running performance of 5000 km
- Running performance of 10000 km

Size 32

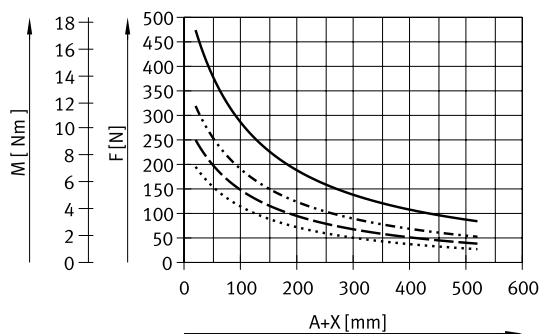

- Running performance of 500 km
- Running performance of 2500 km
- - - Running performance of 5000 km
- Running performance of 10000 km

Size 40

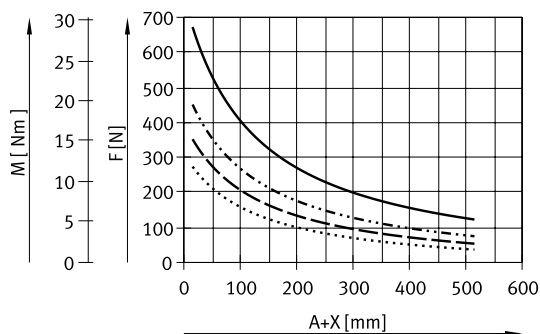

Datasheet

Max. payload F and torque M as a function of projection A

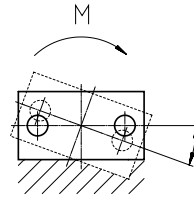
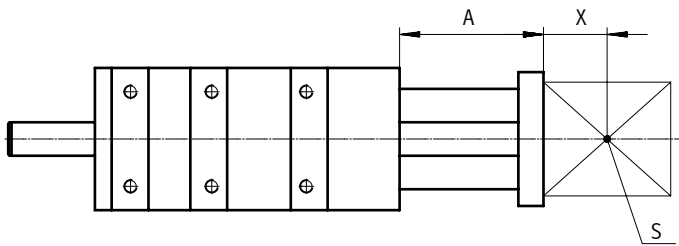

- A = Projection
- X = Distance to centre of gravity of the payload
- S = Centre of gravity of the payload
- M = Torque

Size 50

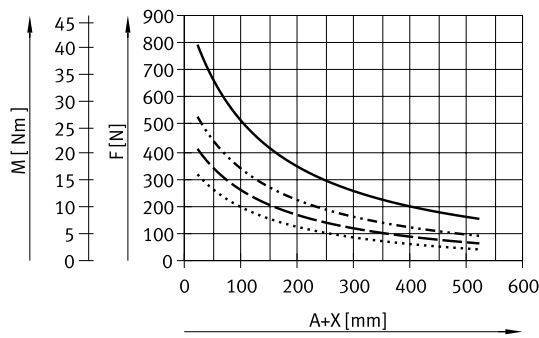

Size 63

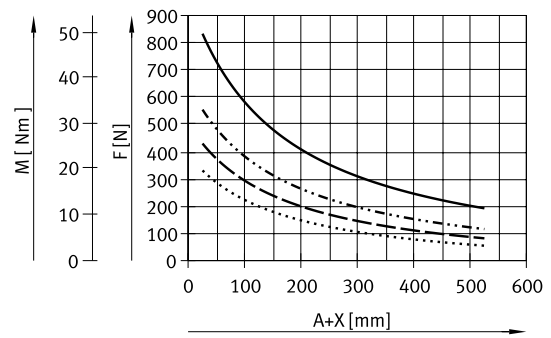

Size 80

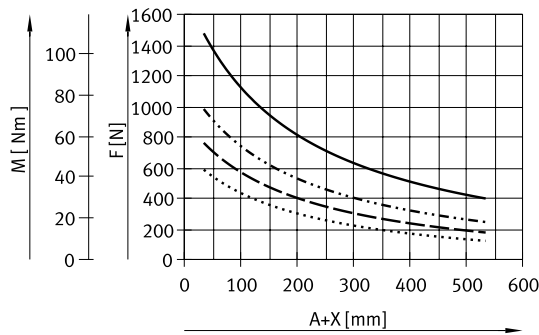

Size 100

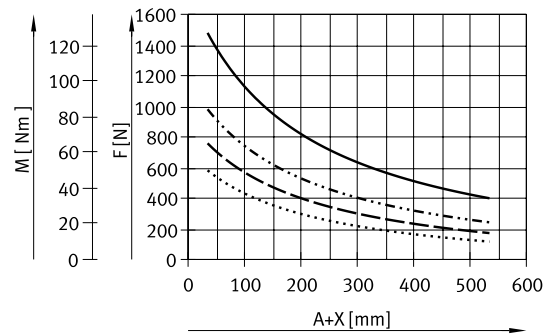

- Running performance of 500 km
- · - · - · Running performance of 2500 km
- Running performance of 5000 km
- Running performance of 10000 km

Datasheet

Deflection f_{dead} (due to dead weight) as a function of projection A

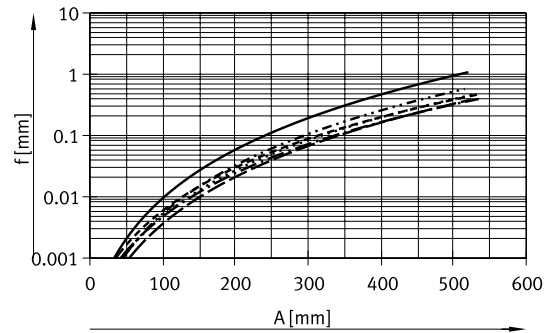
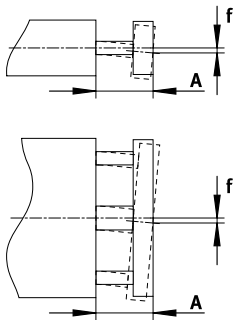

- EAGF-V2-KF-32
- EAGF-V2-KF-40
- - - EAGF-V2-KF-50
- · - · EAGF-V2-KF-63
- - - - EAGF-V2-KF-80
- - - - EAGF-V2-KF-100

Deflection f_{standard} (due to lateral force) as a function of projection A

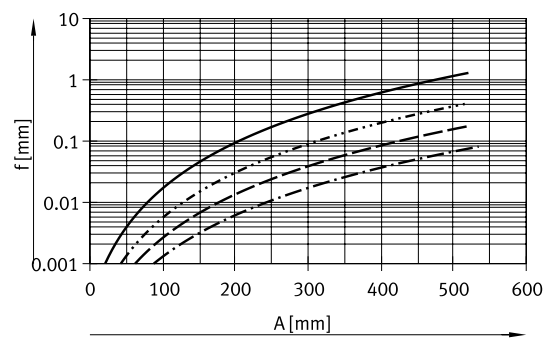
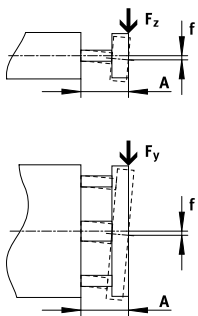

- EAGF-V2-KF-32
- EAGF-V2-KF-40
- - - EAGF-V2-KF-50/
EAGF-V2-KF-63
- · - · EAGF-V2-KF-80/
EAGF-V2-KF-100

The maximum permissible lateral force must not be exceeded.

$$f_1 = \frac{F_1}{F_2} \cdot f_2$$

$$F_2 = 10 \text{ N}$$

A = Projection of guide rod

f_1 = Deflection due to lateral force

F_1 = Lateral force

F_2 = Standardised lateral force

f_2 = Deflection due to standardised lateral force (value from graph)

Incline α (due to torque) as a function of projection A

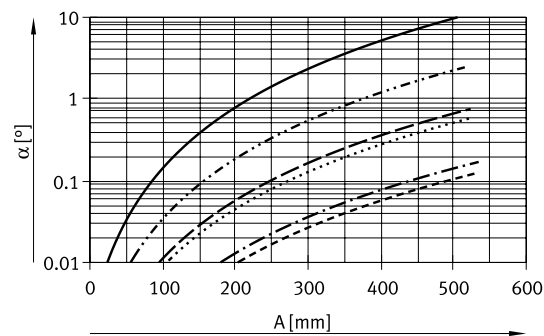
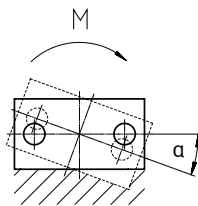

- EAGF-V2-KF-32
- EAGF-V2-KF-40
- - - EAGF-V2-KF-50
- · - · EAGF-V2-KF-63
- - - - EAGF-V2-KF-80
- - - - EAGF-V2-KF-100

$$\alpha_1 = \frac{M_1}{M_2} \cdot \alpha_2$$

$$M_2 = 2 \text{ Nm}$$

(valid for $\alpha \leq 10^\circ$)

A = Projection of guide rod

α_1 = Incline due to torque

M_1 = Torque

M_2 = Standardised torque

α_2 = Deflection due to standardised lateral force (value from graph)

Datasheet

Dimensions

Download CAD data → www.festo.com

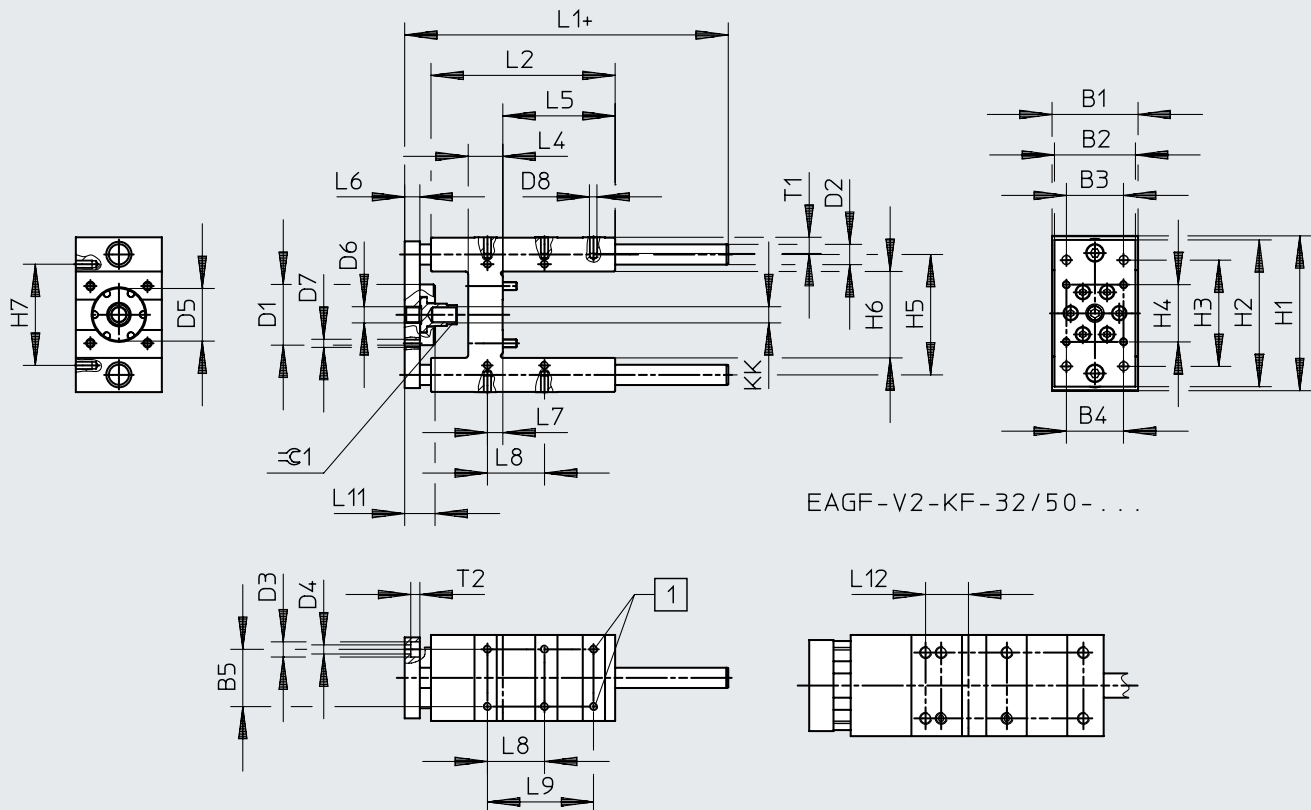

EAGF-V2-KF-32/50-...

[1] These threads are omitted for sizes 80 and 100.

Size	B1	B2	B3	B4	B5	D1 ∅	D2 ∅ h6	D3 ∅	D4 ∅	D5 ∅ H8	D6	D7
	-0.3		±0.2	±0.2	±0.2							
32	50	45	32.5	32.5	32.5	44	12	11	6.6	34	M6	M6
40	58	54	38	38	38	48	16	11	6.6	39	M8	M6
50	70	63	46.5	46.5	46.5	60	20	15	9	45	M8	M8
63	85	80	56.5	56.5	56.5	60	20	15	9	52	M16	M8
80	105	100	72	72	72	78	25	18	11	60	M18	M10
100	130	120	89	89	89	78	25	18	11	70	M18	M10

Size	D8	H1	H2	H3	H4	H5	H6	H7	KK	L1	L2
		-0.5		±0.2	±0.2	±0.2		±0.2		±1	
32	M6	97	90	78	32.5	74	50.5±0.3	61	M10x1.25	154.8	125
40	M6	115	110	84	38	87	58.5±0.3	69	M12x1.25	172.8	140
50	M8	137	130	100	46.5	104	70.5±0.3	85	M16x1.5	187.8	150
63	M8	152	145	105	56.5	119	85.5±0.3	100	M16x1.5	219.8	182
80	M10	189	180	130	72	148	106+1/-0.6	130	M20x1.5	257.8	215
100	M10	213	200	150	89	172	131+1/-0.6	150	M20x1.5	262.8	220

Size	L3	L4	L5	L6	L7	L8	L9	L10	L11	L12	T1	T2	⊕C1
						±0.2	±0.2						
32	69.5 ⁺⁵	24	76	12	4.3	32.5	78	-	21.2±1.7	12	14	6.5	15
40	74.5 ⁺⁵	28	81	15	11	38	84	-	20.3±1.7	-	14	6.5	15
50	94.5 ⁺⁵	34	79	15	18.8	46.5	100	-	25.1±1.7	37	16	9	19
63	96.6	34	111	15	15.3	56.5	105	11	25.3±1.8	-	16	9	19
80	121.6	40	128	20	21	72	-	15	34.1±2.0	-	20	11	27
100	126.6	40	128	20	24.5	89	-	15	34.1±2.0	-	20	11	27

Datasheet

Dimensions – Screw-in depth of the piston rod

Download CAD data → www.festo.com

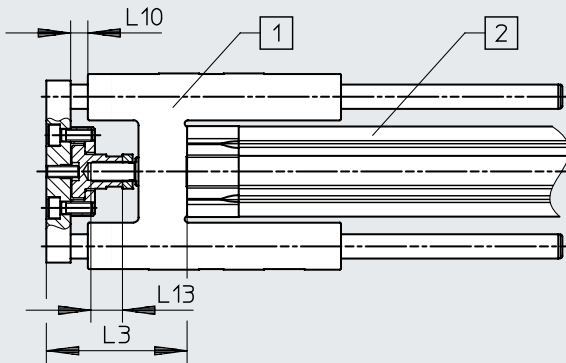

[1] Guide unit

[2] Electric cylinder

The dimensions L3 and L10 are only valid in combination with screw-in depth L13

Size	L3	L10	L13
			±0.2
32	70.2 ±1	9.2 ±1.5	15
40	79.3 ±1	5.3 ±1.5	16
50	96.1 ±0.9	10.1 ±1.5	24
63	96.3 ±1	10.3 ±1.6	24
80	121.1 ±1.1	14.1 ±1.8	30
100	126 ±1.1	14.1 ±1.8	30

Datasheet

★ Core Range

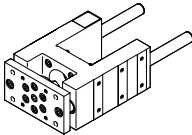
Ordering data				
Guide unit	Size	Stroke [mm]	Part no.	Type
	32	100	★ 2782679	EAGF-V2-KF-32-100
		200	★ 2782818	EAGF-V2-KF-32-200
		320	★ 2782885	EAGF-V2-KF-32-320
		400	★ 2782923	EAGF-V2-KF-32-400
	40	100	★ 2782939	EAGF-V2-KF-40-100
		200	★ 2782976	EAGF-V2-KF-40-200
		320	★ 2783047	EAGF-V2-KF-40-320
		400	★ 2783080	EAGF-V2-KF-40-400
	50	100	★ 2783639	EAGF-V2-KF-50-100
		200	★ 2784152	EAGF-V2-KF-50-200
		320	★ 2784164	EAGF-V2-KF-50-320
		400	★ 2784184	EAGF-V2-KF-50-400
	63	100	★ 1725842	EAGF-V2-KF-63-100
		200	★ 1725843	EAGF-V2-KF-63-200
		320	★ 1725844	EAGF-V2-KF-63-320
		400	★ 1725845	EAGF-V2-KF-63-400

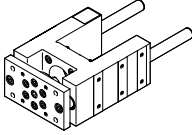
Ordering data					
Guide unit	Size	Stroke [mm]	Part no.	Type	
	32	1 ... 500	3038083	EAGF-V2-KF-32-	
	40	1 ... 500	3038089	EAGF-V2-KF-40-	
	50	1 ... 500	3038094	EAGF-V2-KF-50-	
	63	1 ... 500	2608521	EAGF-V2-KF-63-	
	80	100		1725846	EAGF-V2-KF-80-100
		200		1725847	EAGF-V2-KF-80-200
		320		1725848	EAGF-V2-KF-80-320
		400		1725849	EAGF-V2-KF-80-400
		1 ... 550		2608528	EAGF-V2-KF-80-
	100	100		1725850	EAGF-V2-KF-100-100
		200		1725851	EAGF-V2-KF-100-200
		320		1725852	EAGF-V2-KF-100-320
		400		1725853	EAGF-V2-KF-100-400
		1 ... 550		2608532	EAGF-V2-KF-100-

Datasheet

⊘ Diameter
16, 25, 40 mm

 www.festo.com

┆ Stroke length
50 ... 400 mm

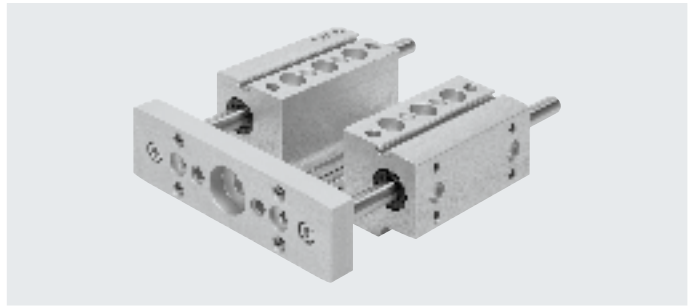

General technical data				
Size		16	25	40
Stroke	[mm]	50, 75, 100, 125, 150, 175, 200	50, 75, 100, 125, 150, 175, 200, 250, 300	50, 75, 100, 125, 150, 175, 200, 250, 300, 350, 400
Design		Guide		
Guide		Recirculating ball bearing guide		
Displacement force	[N]	3.2	4	6
Reversing backlash	[μm]	0		
Permissible speed	[m/s]	1		
Permissible acceleration	[m/s ²]	25		
Type of mounting		Via female thread		
Mounting position		Any		

Operating and environmental conditions				
Size		16	25	40
Ambient temperature	[°C]	0 ... +50		
Storage temperature	[°C]	-20 ... +60		
Relative humidity		0 ... 95 (non-condensing)		
Degree of protection		IP40		
Corrosion resistance class CRC ¹⁾		0		

1) Additional information www.festo.com/x/topic/kbk

Weight [g] (for calculation → page 26)				
Size		16	25	40
Basic weight with 0 mm stroke		600	1080	1910
Additional weight per 10 mm stroke		8	12	18
Moving mass with 0 mm stroke		160	300	560
Additional mass per 10 mm stroke		8	12	18

Centre of gravity of the moving mass [mm] (for calculation → page 26)				
Size		16	25	40
With 0 mm stroke		29	30	36
Supplement per 10 mm stroke		4.5	4.5	4.5

Datasheet

Materials

Sectional view

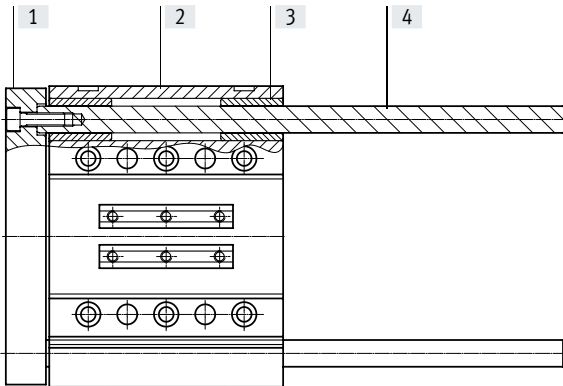

Guide unit		
[1]	Yoke plate	Anodised wrought aluminium alloy
[2]	Housing	Anodised wrought aluminium alloy
[3]	Bearings	Steel
[4]	Guiding rod	Hard-chromium plated tempered steel
-	Note on materials	RoHS-compliant

Load values

The indicated forces and torques refer to the centre of the guide.

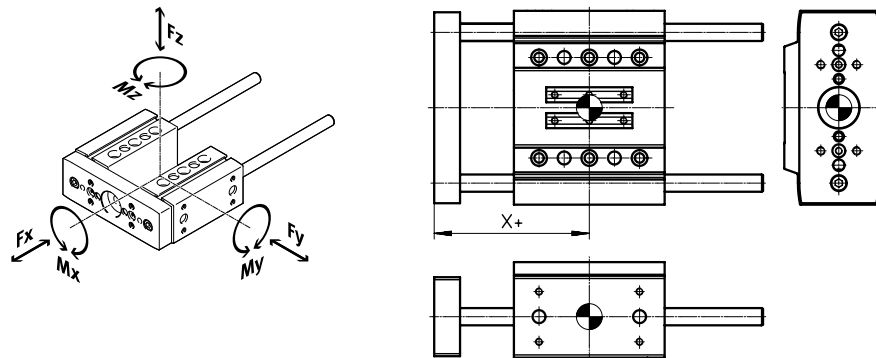

If the guide unit is subjected to several of the indicated forces and torques at the same time, the following equation must be satisfied in addition to the indicated maximum loads:

Calculating the load comparison factor:

$$f_v = \frac{|F_{y1}|}{F_{y2}} + \frac{|F_{z1}|}{F_{z2}} + \frac{|M_{x1}|}{M_{x2}} + \frac{|M_{y1}|}{M_{y2}} + \frac{|M_{z1}|}{M_{z2}} \leq 1$$

F₁/M₁ = dynamic value

F₂/M₂ = maximum value

Distance X (for calculation → page 26)

Size	16	25	40
Dimension X [mm]	51	59	72

Max. permissible forces and torques

Size	16	25	40
Static			
F _y max./F _z max. [N]	355	415	510
M _x max. [Nm]	13	19	27
M _y max./M _z max. [Nm]	9	12	20
Dynamic (for a service life of 5000 km)			
F _y max./F _z max. [N]	160	320	380
M _x max. [Nm]	6	15	20
M _y max./M _z max. [Nm]	4	10	15

Datasheet

Calculating the service life

The service life of the guide depends on the load. To provide a rough indication of the service life of the guide, the graph below plots the load comparison factor f_v against the service life ratio q .

These values are only theoretical. You must consult your local contact person at Festo for load comparison factors f_v greater than 1.5.

Load comparison factor f_v as a function of service life ratio q

Example: The effect on the service life, deviating from the specified reference service life, can be determined using the service life ratio q :

Assuming: Reference service life = 5000 km
Required service life = 3000 km

$$q = \frac{3000 \text{ km}}{5000 \text{ km}} = 0,6$$

The graph gives a load comparison factor f_v of 1.2. This means that the permissible total load can be utilised up to 120%.

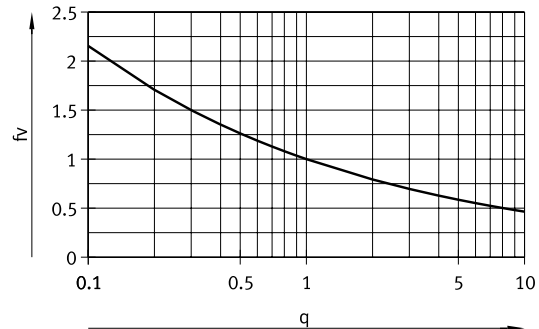

$f_v > 1.5$ are only theoretical comparison values.

Calculation example

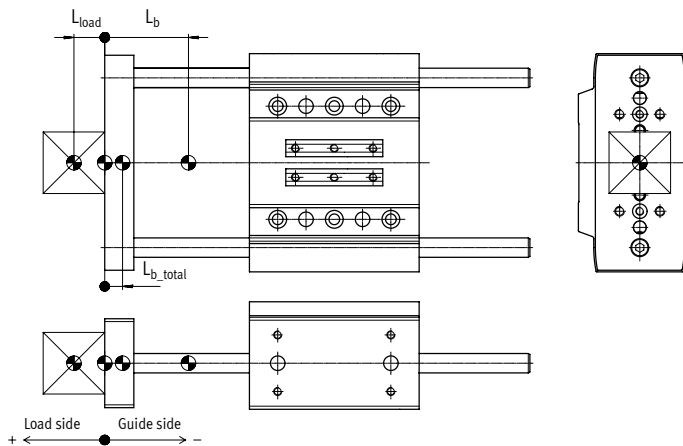

L_b = Centre of gravity of the moving mass of the guide unit

L_{load} = Centre of gravity of payload

L_{b_total} = Centre of gravity of the total moving mass

Length measurements should be provided with plus/minus signs as shown in the figure:

$L_{b_total} > 0$ = Centre of gravity of the moving mass is on the payload side

$L_{b_total} < 0$ = Centre of gravity of the moving mass is on the guide side

Assuming:

- Guide unit: EAGF-P1-KF-25-200
- Stroke length: $H = 200 \text{ mm}$
- Centre of gravity of payload: $L_{load} = 15 \text{ mm}$
- Payload: $m_{Load} = 2 \text{ kg}$
- Acceleration: $a_x = a_y = 2 \text{ m/s}^2$, $a_z = 0 \text{ m/s}^2$

To be determined:

- Loads F_{y_dyn}/F_{z_dyn} and $M_{x_dyn}/M_{y_dyn}/M_{z_dyn}$
- Functional operation with combined load
- Expected service life

Datasheet

Calculation example

Solution:

Moving mass:

$$m_{b_total} = m_b + m_{load} \quad (m_b = m_{0b} + H \times m_{Hb})$$

From table → page 24

$$m_{0b} = 0.3 \text{ kg}$$

$$m_{Hb} = 0.012 \text{ kg/10 mm}$$

$$m_b = 0.3 \text{ kg} + 200 \text{ mm} \times 0.012 \text{ kg/10 mm} = 0.54 \text{ kg}$$

$$m_{b_total} = 0.54 \text{ kg} + 2 \text{ kg} = 2.54 \text{ kg}$$

m_b = Moving mass of the guide unit

m_{0b} = Moving mass with 0 mm stroke

m_{Hb} = Additional mass per 10 mm stroke

H = Stroke length

Centre of gravity of the moving mass

$$L_{b_ges} = \frac{L_1 \cdot m_1 + L_b \cdot m_b}{m_{b_ges}} \quad (L_b = L_{0b} + H \times L_{Hb})$$

From table → page 24

$$L_{0b} = 30 \text{ mm}$$

$$L_{Hb} = 4.5 \text{ mm/10 mm}$$

$$L_b = 30 \text{ mm} + 200 \text{ mm} \times 4.5 \text{ mm/10 mm} = 120 \text{ mm}$$

$$L_{b_ges} = \frac{(+15 \text{ mm}) \cdot 2 \text{ kg} + (-120 \text{ mm}) \cdot 0.54 \text{ kg}}{2.54 \text{ kg}} = -14 \text{ mm}$$

L_b = Centre of gravity of the moving mass of the guide unit

m_b = Moving mass of the guide unit

L_1 = Centre of gravity of payload

m_1 = Payload

L_{0b} = Centre of gravity of the moving mass with 0 mm stroke

L_{Hb} = Additional centre of gravity of the moving mass per 10 mm stroke

Length measurements should be provided with plus/minus signs as shown in the figure:

$L_{b_total} > 0$ = Centre of gravity of the moving mass is on the payload side

$L_{b_total} < 0$ = Centre of gravity of the moving mass is on the guide side

Loads F_{y_dyn}/F_{z_dyn} and $M_{x_dyn}/M_{y_dyn}/M_{z_dyn}$

$$F_{y_dyn} = m_{b_total} \times a_y = 2.54 \text{ kg} \times 2 \text{ m/s}^2 = 5 \text{ N}$$

$$F_{z_dyn} = m_{b_total} \times (g + a_z) = 2.54 \text{ kg} \times (9.81 \text{ m/s}^2 + 0 \text{ m/s}^2) = 25 \text{ N}$$

From table → page 25

Dimension X = 59 mm

$$M_{y_dyn} = F_{z_dyn} \times (\text{dimension X} + \text{stroke} + L_{b_total}) = 25 \text{ N} \times (59 \text{ mm} + 200 \text{ mm} + (-14 \text{ mm})) = 6.1 \text{ Nm}$$

$$M_{z_dyn} = F_{y_dyn} \times (\text{dimension X} + \text{stroke} + L_{b_total}) = 5 \text{ N} \times (59 \text{ mm} + 200 \text{ mm} + (-14 \text{ mm})) = 1.2 \text{ Nm}$$

Functional operation with combined load

Max. values from table → page 25

$$F_{y_max} = 320 \text{ N}$$

$$F_{z_max} = 320 \text{ N}$$

$$M_{x_max} = 15 \text{ Nm}$$

$$M_{y_max} = 10 \text{ Nm}$$

$$M_{z_max} = 10 \text{ Nm}$$

$$f_v = \frac{|F_{y1}|}{F_{y2}} + \frac{|F_{z1}|}{F_{z2}} + \frac{|M_{x1}|}{M_{x2}} + \frac{|M_{y1}|}{M_{y2}} + \frac{|M_{z1}|}{M_{z2}} \leq 1$$

$$f_v = \frac{5 \text{ N}}{320 \text{ N}} + \frac{25 \text{ N}}{320 \text{ N}} + \frac{0 \text{ Nm}}{15 \text{ Nm}} + \frac{6.1 \text{ Nm}}{10 \text{ Nm}} + \frac{1.2 \text{ Nm}}{10 \text{ Nm}} = 0.8 \leq 1$$

F_1/M_1 = dynamic value

F_2/M_2 = maximum value

Expected service life

$$L = \frac{L_{ref}}{f_v^3} = \frac{5000 \text{ km}}{0.8^3} = 9000 \text{ km}$$

Datasheet

Max. payload F and torque M as a function of projection A

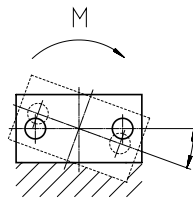
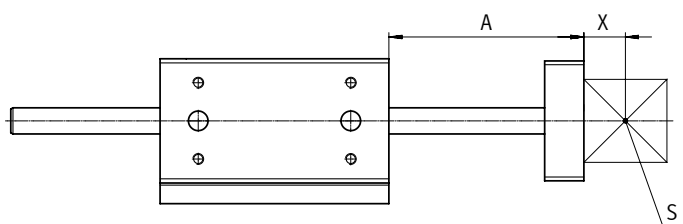

- A = Projection
- X = Distance to centre of gravity of the payload
- S = Centre of gravity of the payload
- M = Torque

Explanation of how to read the graphs in the case of a combined load

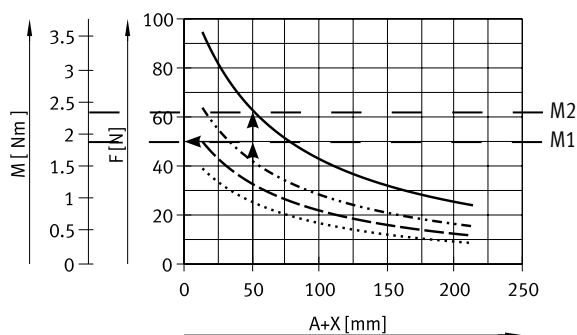

- Determine projection (50 mm)
- Enter lateral force (50 N)
- Enter distance from curve
- Permitted torque is the difference between M2 and M1

- Running performance of 500 km
- · - · - Running performance of 2500 km
- - - Running performance of 5000 km
- Running performance of 10000 km

Size 16

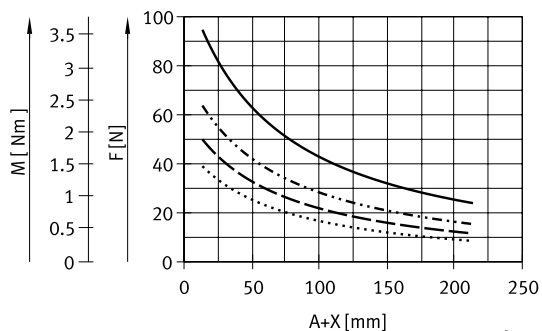

Size 25

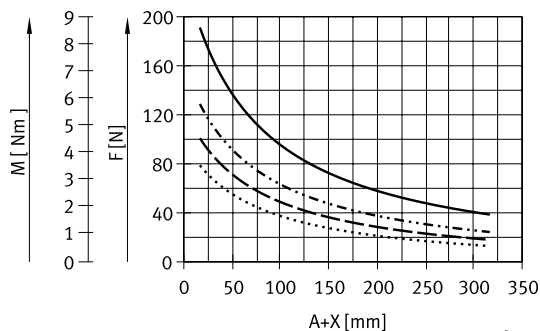

Size 40

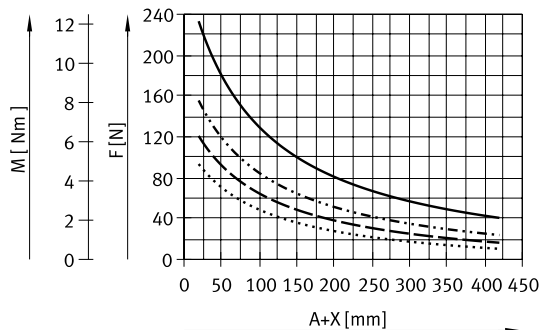

- Running performance of 500 km
- · - · - Running performance of 2500 km
- - - Running performance of 5000 km
- Running performance of 10000 km

Datasheet

Deflection f_{dead} (due to dead weight) as a function of projection A

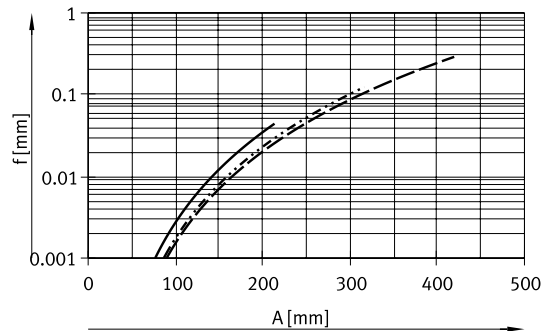
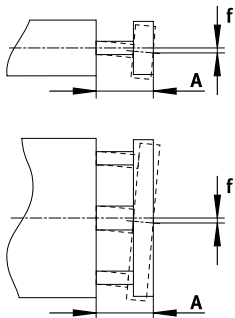

— EAGF-P1-KF-16
 EAGF-P1-KF-25
 - - - EAGF-P1-KF-40

Deflection f_{standard} (due to lateral force) as a function of projection A

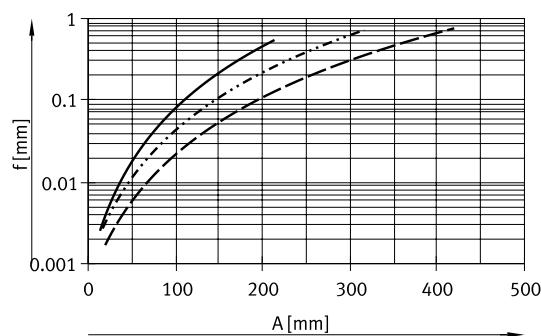
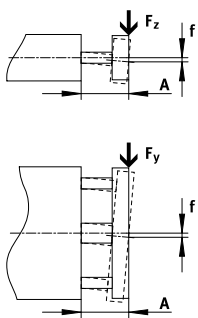

— EAGF-P1-KF-16
 EAGF-P1-KF-25
 - - - EAGF-P1-KF-40

The maximum permissible lateral force must not be exceeded.

$$f_1 = \frac{F_1}{F_2} \cdot f_2$$

$$F_2 = 10 \text{ N}$$

A = Projection of guide rod

f_1 = Deflection due to lateral force

F_1 = Lateral force

F_2 = Standardised lateral force

f_2 = Deflection due to standardised lateral force (value from graph)

Incline α (due to torque) as a function of projection A

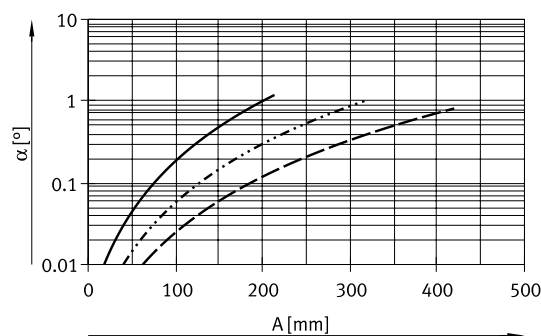
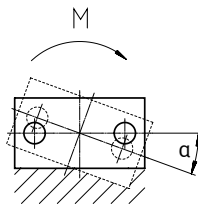

— EAGF-P1-KF-16
 EAGF-P1-KF-25
 - - - EAGF-P1-KF-40

$$\alpha_1 = \frac{M_1}{M_2} \cdot \alpha_2$$

$$M_2 = 2 \text{ Nm}$$

(valid for $\alpha \leq 10^\circ$)

A = Projection of guide rod

α_1 = Incline due to torque

M_1 = Torque

M_2 = Standardised torque

α_2 = Deflection due to standardised lateral force (value from graph)

Datasheet

Possible combinations with other drives/axes via direct mounting

Guide unit EAGF with electric cylinder EPCO and guide unit EAGF

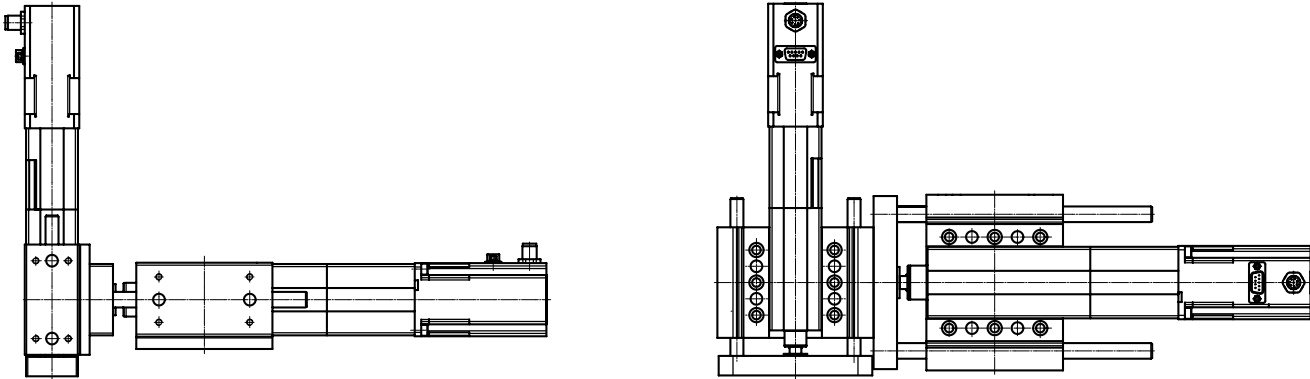

Size	Base axis	
	EAGF-P1-KF-25	EAGF-P1-KF-40
Assembly axis		
EAGF-P1-KF-16	■	-
EAGF-P1-KF-25	-	■

Toothed belt axis ELGR with electric cylinder EPCO and guide unit EAGF

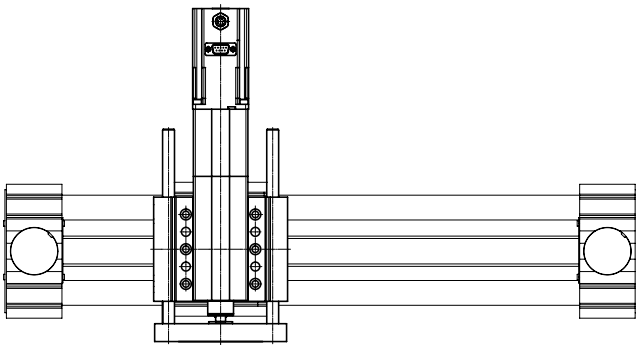

Size	Base axis		
	ELGR-TB-35	ELGR-TB-45	ELGR-TB-55
Assembly axis			
EAGF-P1-KF-16	■	-	-
EAGF-P1-KF-25	-	■	-
EAGF-P1-KF-40	-	-	■

Datasheet

Possible combinations with other drives/axes via direct mounting

Rotary drive ERMO with electric cylinder EPCO and guide unit EAGF

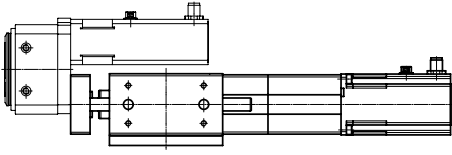

Size	Base axis		
	EAGF-P1-KF-16	EAGF-P1-KF-25	EAGF-P1-KF-40
Assembly axis			
ERMO-12	■	-	-
ERMO-16	-	■	-
ERMO-25	-	-	■

Mini slide DGSL with electric cylinder EPCO and guide unit EAGF

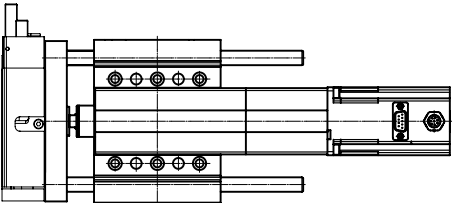

Size	Base axis		
	EAGF-P1-KF-16	EAGF-P1-KF-25	EAGF-P1-KF-40
Assembly axis			
DGSL-8-40 ¹⁾	■	-	-
DGSL-10-30 ¹⁾	-	■	-
DGSL-12-40 ¹⁾	-	-	■

1) Minimal stroke

Datasheet

Dimensions

Download CAD data → www.festo.com

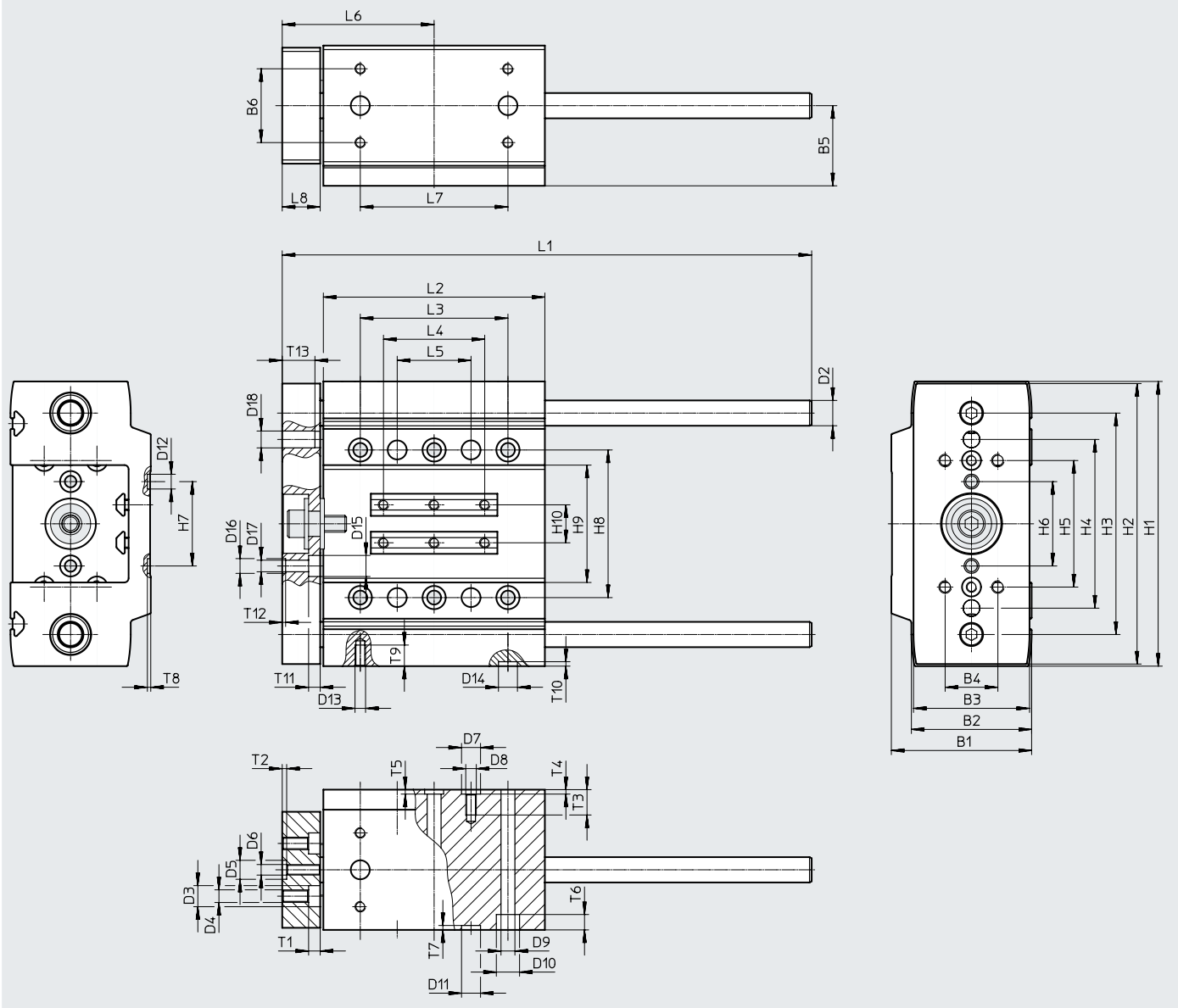

Size 16

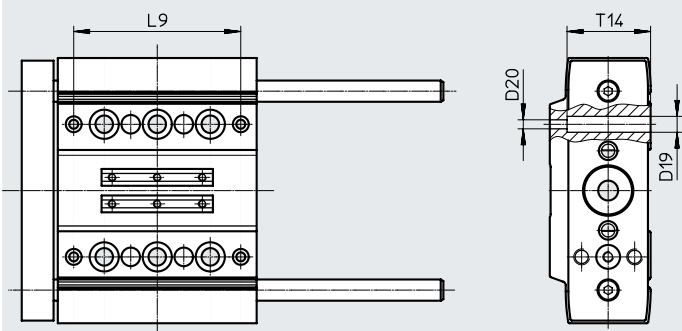

Datasheet

Size	B1	B2	B3	B4 ±0.05	B5	B6 ±0.05	D2 ∅ h7	D3 ∅	D4 ∅	D5 ∅ H8	D6	D7 ∅ H8
16	38	32	30	20	22	20	8	–	M6	9	M4	9
25	50	42	40	20	29	25	10	10	M6	9	M4	9
40	66.5	57	55	25	38	35	12	10	M6	9	M5	9

Size	D8	D9 ∅	D10 ∅	D11 ∅ H8	D12 ∅ H8	D13	D14 ∅ H8	D15 ∅	D16 ∅ H8	D17 ∅	D18 ∅ H7	D19 ∅
16	M5	6.6	11	7	7	M5	9	8	7	5 ^{H7}	–	6
25	M5	6.6	11	9	7	M5	9	10	7	5.5	5	–
40	M5	6.6	11	9	7	M5	9	10	7	5.5	8	–

Size	D20 ∅	H1	H2	H3	H4 ±0.05	H5 ±0.05	H6 ±0.05	H7 ±0.05	H8 ±0.05	H9	H10
16	3.4	100	98	75	–	50	30	30	50	30.7	10
25	–	120	118	90	70	50	33	40	60	40.7	14
40	–	135	133	105	80	60	40	40	70	55.7	18

Size	L1	L2	L3 ±0.05	L4	L5 ±0.05	L6	L7 ±0.05	L8	L9 ±0.1	T1	T2 +0.1
16	109 + stroke	75	40	34	20	51	50	12	63	–	2.1
25	124 + stroke	85	50	40	25	59	60	15	–	5.5	2.1
40	151 + stroke	105	70	48	35	72	70	18	–	5.5	2.1



Size	T3	T4 +0.1	T5 +0.1	T6	T7 +0.1	T8 +0.1	T9	T10 +0.1	T11	T12 +0.1	T13 ±1	T14
16	15.5	2.1	2.1	6.5	1.6	1.6	8.5 _{-0.5}	2.1	4.4	1.6	–	31.5
25	14	2.1	2.1	6.4	2.1	1.6	min.10	2.1	5.7	1.6	12.5	–
40	12	2.1	2.1	7.3	2.1	1.6	min.10	2.1	5.5	1.6	15.5	–

Datasheet

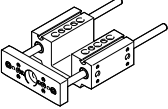
★ Core Range

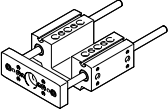
Ordering data				
Guide unit	Size	Stroke [mm]	Part no.	Type
	16	50	★ 3192932	EAGF-P1-KF-16-50
		100	★ 3192934	EAGF-P1-KF-16-100
		150	★ 3192936	EAGF-P1-KF-16-150
		200	★ 3192938	EAGF-P1-KF-16-200
	25	50	★ 3192943	EAGF-P1-KF-25-50
		100	★ 3192945	EAGF-P1-KF-25-100
		150	★ 3192947	EAGF-P1-KF-25-150
		200	★ 3192949	EAGF-P1-KF-25-200
		300	★ 3192951	EAGF-P1-KF-25-300
	40	50	★ 3192955	EAGF-P1-KF-40-50
		100	★ 3192957	EAGF-P1-KF-40-100
		150	★ 3192959	EAGF-P1-KF-40-150
		200	★ 3192961	EAGF-P1-KF-40-200
		300	★ 3192963	EAGF-P1-KF-40-300

Ordering data				
Guide unit	Size	Stroke [mm]	Part no.	Type
	16	75, 125, 175	3192939	EAGF-P1-KF-16-
	25	75, 125, 175, 250	3192952	EAGF-P1-KF-25-
	40	75, 125, 175, 250 350, 400	3192966	EAGF-P1-KF-40-

Accessories					
Ordering data					
	For size	Description	Part no.	Type	PU ¹⁾
Centring sleeve					
	16, 25, 40	For centring the drive or attachments	8146544	ZBH-7-B	10
			8137184	ZBH-9-B	
Connector sleeve					
	16	For centring the drive or attachments	548805	ZBV-9-7	10

1) Packaging unit